

**CALIFORNIA BUILDING CODES
INSTITUTE AND CALIFORNIA
BUILDING OFFICIALS**

PRESENT

**A SEMINAR ON THE DEPARTMENT OF HOUSING
AND COMMUNITY DEVELOPMENT DISABLED
ACCESSIBILITY AND ADAPTABILITY STANDARDS**

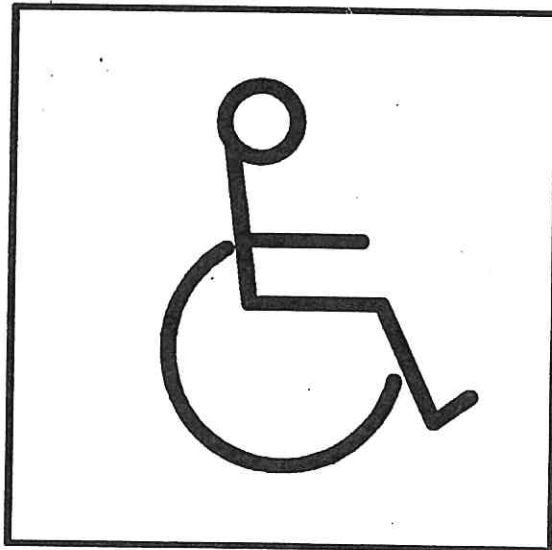

SEMINAR CURRICULUM AND TRAINING WORKBOOK

FALL 1989

ACKNOWLEDGEMENTS

This training program is sponsored by the California Building Codes Institute (CBCI) and California Building Officials (CALBO), a non-profit association of city and county building code enforcement professionals. CBCI was created by CALBO in 1986 to provide professional advancement and continuing education opportunities to building department personnel. Partial funding for this project was provided by the Department of Housing and Community Development.

Assistance in the development of curriculum for this program was provided by representatives of groups affected by these regulations. We appreciate the advice and input received relative to the workbook from the following individuals:

Richard T. Conrad, AIA, Executive Director, California Building Standards Commission

Sam Dardick, Director, Foundation of Resources for Equality and Employment for the Disabled

Lorin Gardner, Building Official, City of Davis

Robert Raymer, P.E., Technical Director, California Building Industry Association

Richard Skaff, Disability Access Coordinator, San Francisco Bureau of Building Inspection, City and County of San Francisco

Miguel Mejia, State Housing Law Program Manager, Department of Housing and Community Development

Chuck McNamee, Assistant Programs Manager, Department of Housing and Community Development

Ed King, Assistant Chief, Division of Codes and Standards, Department of Housing and Community Development

We also wish to acknowledge the participation and effort of the following workshop instructors:

Robert Baker, Manager of Code Enforcement, County of Sacramento

James W. Barthman, P.E., Manager, Inspectional Services, City of Oakland

David J. Martinez, Chief Building Official, City of Redlands

George W. Field, Building Official, City of Oceanside

Lorin Gardner, Building Official, City of Davis

Al Wedderburn, Chief Building Inspector, City of Santa Maria

Neil G. Rains, AIA, Building and Safety Division Manager, City of Fresno

Ed Wilczak, Manager, Building Department Services, Esgil Corporation

Richard C. Peters, P.E., Structural Engineer Associate, City of Los Angeles

James J. Miller, Chief Technical Inspector, County of Riverside

Other contributions to this project were made by Ilene Connerly and Bob Berna of Connerly and Associates, Inc. Marketing assistance was provided by the California Council, American Institute of Architects, the California Building Industry Association and the Department of Housing and Community Development. Ann E. Muller served as coordinator for this training project.

SEMINAR AGENDA AND TABLE OF CONTENTS

Chapter	Page
I. Introduction	1-6
• <i>Workbook Organization</i>	<i>1</i>
• <i>Recent Amendments to Title 24</i>	<i>2</i>
• <i>Accessibility and Adaptability</i>	<i>3</i>
• <i>Needs of a Changing Population</i>	<i>3-4</i>
• <i>Purpose of the Regulations</i>	<i>4-5</i>
II. Understanding and Enforcing Title 24	6
III. The Accessibility and Adaptability Standards	7-32
• <i>Scope and Application</i>	<i>7-8</i>
• <i>Circulation Components</i>	<i>9-21</i>
• <i>Height Components</i>	<i>22</i>
• <i>Bathroom Components</i>	<i>23-29</i>
• <i>Kitchen Components</i>	<i>30-32</i>
IV. Information on Pending Federal Regulations	33-34
V. Typical Questions and Answers	35-38
VI. Where to Obtain Assistance	39-40
• <i>Resource Materials</i>	<i>39</i>
• <i>Roster of Individuals and Associations</i>	<i>40</i>
Appendix I. Interpretations	41

I. Introduction - Workbook Organization

This workbook is organized to be a useful resource in understanding Title 24 and other applicable sections relative to enforcement of the state disabled accessibility/adaptability regulations. Although the applicable code sections are quoted in this workbook, it is designed to be used in conjunction with Title 24. You may wish to refer to the California amendments to the Uniform Building Code to see where they appear in the code manual. A New Horizon, published by the Department of Housing and Community Development, also serves as a resource for people enforcing these regulations. A New Horizon may be obtained from the Department of Housing and Community Development.

Chapter I of the workbook provides background information on the development of the California accessibility/adaptability regulations. This chapter begins with a summary of recent amendments to Title 24. It is followed by a discussion of the concept on which the accessibility regulations are based, a description of the needs of the disabled community, and an explanation of the purpose of the regulations.

Chapter II is a discussion of the Title 24 process in California. The focus of this chapter is to help you understand and enforce Title 24. Title 24 is now being published by the International Conference of Building Officials (ICBO). The chapter will provide information on how to use Title 24 in its new publication format.

Chapter III is a technical discussion of the code requirements. For clarity, it is divided into five discussion groups beginning with a section on scope and application. This is followed by discussions of circulation components, height components, bathroom components, and kitchen components. Each of these sections cites the applicable code section(s) from Title 24 (and may reference the previous code section which is being replaced) and, when necessary, is followed by a discussion relative to enforcement of the requirements. *Italics indicate code language, and bars in the margin show the amendments which become effective January 1, 1990.* Illustrations, where appropriate, are incorporated in the discussion.

Chapter IV contains important information on pending federal regulations. The Federal Fair Housing Amendments Act of 1988 was signed into law in 1988. The act will have an impact on enforcement and compliance beginning in January 1990.

Chapter V provides basic questions and their answers for discussion and reference. Opportunities will be provided during the seminar for more discussion of how these regulations are to be understood and enforced. The Department of Housing and Community Development, however, issues formal interpretations of these regulations.

Chapter VI contains information on how to obtain resource materials. A roster including the names, addresses, and phone numbers of people and/or organizations who are knowledgeable about these regulations is also available. Finally, space for formal interpretations issued by the Department of Housing and Community Development is provided for in the back of the workbook.

Recent Amendments to Title 24

On January 20, 1989, the California Building Standards Commission approved amendments to the accessibility/adaptability regulations adopted by the Department of Housing and Community Development (HCD) and contained in Title 24. These regulations became effective at the state level on July 1, 1989 and will become effective at the local level on January 1, 1990.

The process of determining where changes in existing laws were needed was a lengthy one. In August 1986, HCD appointed a Disabled Access Advisory Committee to study the concerns which had surfaced during the preceding years of the accessibility and adaptability regulations.

Three important changes were approved: (1) repeal of the cost cap; (2) a requirement that 5% of apartment dwellings on the building site comply fully with the disability access regulations and (3) a requirement that all other accessible units also would be required to have accessible and adaptable features. A brief summary of each of these changes is provided below:

Repeal of Cost Cap

Local building departments found enforcement of the "cost cap", as required in the previous regulations, to be very difficult. The process of verifying compliance with a expenditure ceiling was troublesome for building inspectors. Moreover, units constructed according to the cost cap provision often would have a variety of adaptable features, but a person with a physical disability could not get into the unit.. It was determined that the cost cap had to be eliminated. What would replace it, however, was the topic of long discussions among the affected parties.

Full Compliance in Five Percent of Apartment Units

To address the need for fully accessible apartment units, the California Building Standards Commission approved an amendment that 5% of apartment units on a building site must comply fully with the accessibility regulations. This means the accessibility and adaptability requirements apply to not less that the following number of apartment dwelling units on a building site:

- *5 through 20 - one unit*
- *21 and over - one, plus one for each additional 20 units or fraction thereof.*

Mandatory Features in Other Accessible Units

All other apartment units on primary-entrance floors and other floors above or below the primary-entrance floor served by a ramp, elevator, or special lift also must comply with the accessibility and adaptability requirements. Only the kitchens in these units are exempt from being compliance with the HCD regulations described in this workbook.

Accessibility and Adaptability

When speaking of accessible design and construction, some people think, first, of accessibility for persons who use wheelchairs. It is important to note, however, that physical disabilities and related limitations exist for a much greater number of people than previously thought. Heart conditions, emphysema, arthritis, and other non-visible conditions, as well as aging, can result in disabilities which do not allow for the type of movement that many of us take for granted. Accessible and adaptable housing, therefore, is designed to provide housing opportunities to a growing population of persons with disabilities.

Most designers are familiar with the ANSI accessibility standards for public buildings. These and variants on them have been used in HUD-subsidized buildings for many years to create a percentage, usually 1% to 5%, of units in a large project which are accessible for the persons with physical disabilities. To be useful for a person with disabilities, accessible and adaptable housing must provide such features as backing for the installation of grab-bars at the water closet, an adequate turning area in the kitchen and other single-exit areas, lever door hardware and lowered kitchen counter tops. While these features can accommodate a person who uses a wheelchair, assistive devices such as lever hardware and grab bars can be essential for an elderly person, a person with arthritis, and for persons who may be temporarily disabled.

Adaptable housing is a design concept in which dwelling units may be adapted to meet the needs of occupants with different disabilities. Adaptable housing, of course, is initially accessible for persons using wheelchairs in terms of entry and circulation, but also can be adapted to the use of people with a variety of disabilities through minor low-cost modifications after construction.

To an able-bodied occupant, an adaptable unit may appear no different than any other, except that circulation may be somewhat easier. To a person in a wheelchair, the home may be adapted to his or her use by lowering a work area in the kitchen to be comfortably used when seated. To a person with other physical disabilities who does not need a lowered work area, the home may be adapted in other ways. An elderly person with increasing mobility limitations may wish to install grab bars in the bathroom. The performance standard for adaptable home design also allows an able-bodied person who becomes disabled to have the ability to get into and out of the home, to circulate freely within it, and to perform basic daily functions in the kitchen and bathroom. Title 24 (Parts 2,3, and 5) of the California Code of Regulations provide a minimal prescription for achieving this design goal.

The Needs of a Changing Population

The baby boom generation is coming of age and, as a result, the American population is aging. The population over 60 years old has risen from 12% in 1950 to 16% in 1980. (Source: 1980 Census). With better nutrition and advances in medical technology, that

population will become significantly greater in the 1990's. For seniors today, the older years are healthier and more productive. If their living accommodations can be quickly and inexpensively adapted, our older population will be able to live independently and productively at home, avoiding expensive and sometimes dehumanizing institutionalization.

The population of persons with disabilities has changed significantly, too. Improved medical care allows many people to live longer and more productive lives. Independent living - at home - is not only less costly to our nation, but also allows continued access to school, to work, to friends' homes, recreation, shopping, and public transportation. Like those who are aging, persons with disabilities are not only living longer, but have increased expectations for their own ability to fully participate in society on the job, at school, and socially.

The purpose of accessible and adaptable housing is to design housing for the largest market possible, regardless of age or physical condition. Adaptable housing, as we now understand it, is California's attempt to tailor housing to the changing needs of our much older and more diverse population.

Purpose and Performance Goals of the Regulations

The purpose of these adaptability regulations is to recognize the housing needs of the wide range of California residents. These regulations address specific design points which create new rental housing units for persons with specific needs or a disabling condition.

These regulations, therefore, attempt to ensure that all rental housing will allow for accessible use by persons with disabilities, including those who are aging. The goal is to build housing which can accommodate those who are aging, and, therefore, prevent elderly people from being displaced from their homes if they suffer a heart attack or broken hip, and to provide more housing options to people with physical disabilities.

An apartment occupant must be able to move from the edge of the site, through all public areas indoors and out, to a specific unit's main entrance and through all rooms of the apartment. The net clear door opening widths must be wide enough (32") to admit a person using a wheelchair or walker. The corridors must be spacious enough (44") to make a 90 degree turn in a wheelchair through a side doorway. Within the unit, however, corridor widths may be reduced to a minimum width of 36 inches. Also, the door handles must be usable by those with limited grasping ability, and shelves, control switches, outlets, and thermostats must be operable within required height specifications in compliance with Title 24 of the California Code of Regulations.

Typically, the use of various functional areas are taken for granted - except when a shelf is too high to see its contents, when the toilet paper dispenser is not within grasp, when the bedroom doorway will not allow a person using a wheelchair to enter, or when an electrical outlet is too low on the wall. These and other items may be inconvenient or

annoying to the able-bodied, but may be an insurmountable obstacle for a person who must maneuver using a wheelchair of fixed dimensions and weight or a person with arthritis who cannot bend, stretch, or grasp.

A person using the kitchen also needs safe and comfortable access to stove, sink, and refrigerator, and must have adequate counter space to prepare foodstuffs, and reachable storage for pots, implements, and food. The difference in height between a seated and standing person is approximately 15". A person who is disabled, therefore, has a range of comfort and safety which is more limited than an able-bodied person. This difference in eye height, also, makes shelf location and placement of switches important. Most people who use wheelchairs have a different center of gravity than a standing person, and reaching below it may result in a loss of balance.

The kitchen, where the bulk of daily activity takes place, is made safer and more usable by these regulations and will be discussed in detail further in the text under "Kitchen Components".

Another area of concern is the bathroom, where one uses the sink, toilet, and either a tub or shower. In this room, the most important focus is the maneuvering room needed for a bathroom to be useable for a person who is mobility-impaired. For a person using a wheelchair to be safe and comfortable in performing necessary daily activities, he or she must be able to go into the bathroom, shut the door, use the toilet and the sink, and then reopen the door and exit.

Because bathroom areas rarely are given more than residual space, the maneuvering area is usually inadequate. A person transferring to a toilet from a wheelchair needs space in front or on the side for that transfer. The sink or vanity must be usable from a front position with hot and cold water faucet controls reachable from a wheelchair. A space would be needed beside the tub of sufficient size to allow parallel parking of the wheelchair for transfer to the bathtub. The tub/shower would then be accessible from a seated position.

If the maneuvering space within the room is inadequate, the bathroom will be unusable for a person in a wheelchair. A person using a walker, cane, or assistive device also will need room to shift weight and balance when positioning to use the bathroom facilities. Design implications of necessary maneuvering space will be discussed in the "Bathroom Components" section of the workbook.

In conclusion, it must be remembered that the regulations described in the following pages were developed to allow persons with disabilities to gain access to housing in California.

II. UNDERSTANDING AND ENFORCING TITLE 24

The complete set of accessibility/adaptability regulations for new apartment buildings was developed and adopted by the Department of Housing and Community Development and was approved by the California Building Standards Commission in December 1983. The standards were published in the 1984 Annual Supplement to the State Building Code on March 15, 1985 and became effective at the local level on September 15, 1985. The most recent changes will become effective for local enforcement on January 1, 1990.

Title 24 contains amendments which have been made by state agencies to the Uniform Building Code. Beginning with the 1988 UBC, state amendments to the Uniform Building Code will be printed by ICBO as "California Supplements" to be incorporated into the loose leaf edition of the UBC. The California amendments are also published in booklet form and are available from ICBO.

All state agencies which have programs that include building standards are required to develop their standards so that they closely follow the requirements of the Uniform Building Code. Many agencies, such as the Department of Housing and Community Development, which has jurisdiction over residential occupancies, adopt the Uniform Building Code by reference. That is, they simply refer the designer or enforcement official to the Uniform Building Code for construction requirements.

When a state agency determines a need for amendments or additions to the Uniform Building Code, they adopt such changes after a public hearing process. These changes are reviewed by the California Building Standards Commission, which analyzes the proposed code based on an established criteria. When approved by the California Building Standards Commission, the amendments are published by ICBO as "California Supplements" to the Uniform Building Code. In statute, they appear in Title 24, Part 2 of the California Code of Regulations.

Once adopted by the state, a local government must adopt the provisions of the code amendments. Local enforcement cannot begin until six months have passed from the publication date of the regulations, or six months from another date set by the California Building Standards Commission. This delay is largely for the benefit of the construction industry. It allows designers, builders, and developers to become familiar with elements of the code and also serves to clear the pipeline of projects which have been designed to the previous building standard.

It is important to note that some aspects of the accessibility and adaptability regulations may appear in other parts of Title 24 or in the model codes. A limited number of electrical requirements appear in Part 3 (NEC) of Title 24. There are also a limited number of plumbing requirements which appear in Part 5 (UPC) of Title 24.

III. THE ACCESSIBILITY/ADAPTABILITY STANDARDS

Scope of the Regulations

Applicable Code Section 110A(b)9 [Formerly Section 2-110(b)9] Application – Hotels, motels, lodging houses, apartment houses, dwellings, employee housing and factory-built housing. Accessibility and adaptability requirements for the physically handicapped shall apply to all privately funded apartment houses of five (5) or more dwelling units where an application for a building permit is submitted after the effective date of these regulations within a local agency. These regulations do not apply to condominiums, coops, and townhouses.

Instructor's Notes: The first sentence of the above "application" section may be misleading to those unfamiliar with state housing law. This sentence simply refers to those areas over which the Department of Housing and Community Development has jurisdiction.

The accessibility and adaptability regulations do not apply to all of the building types listed in the first sentence of this paragraph - they only apply to privately funded apartment houses having five or more units. Specific requirements for the above areas are found in Chapters 5, 12, and 33.

There is no definition of townhouse included in the standards. The intent of the Department of Housing and Community Development was to exempt those townhouse projects which are two-story, single-family attached units having two-hour fire wall construction and an ownership of the airspace. Apartment units constructed in the two-story townhouse style would have to comply with these regulations if they contained all of the elements of a dwelling unit on their accessible floor. These elements include bathroom, kitchen facilities, dining area, and sleeping rooms. If these elements are present, the regulations would be in force on the accessible floor only.

The standards state that the total number of apartment houses on a site shall be considered as one building. Apartments, as defined by the Uniform Building Code, contain three or more dwelling units.

Exhibit 1.

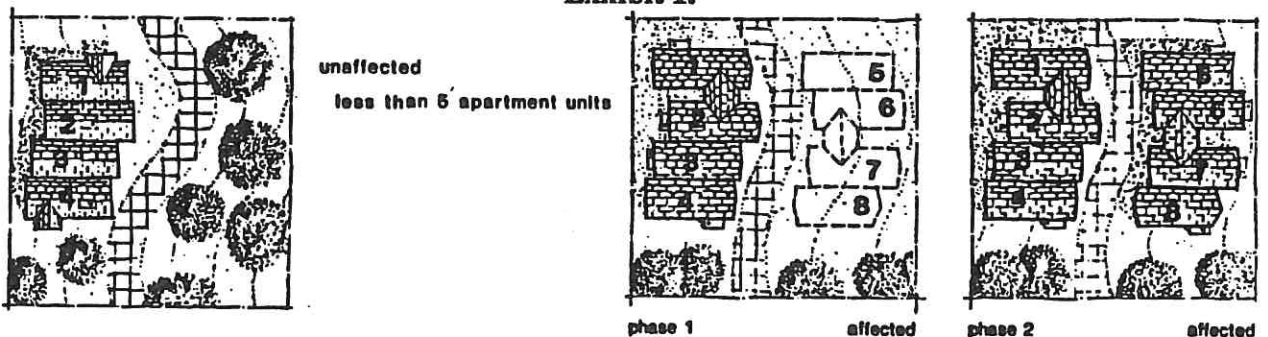

(Figure 1 illustrates a project that would not be subject to these regulations because there are less than five apartment units on the building site; Figure 1 contains only four apartment buildings on the site.)

[Figures 2 and 3 illustrate a two-phase project built on the same parcel. Even though only four units were built on the site in the first phase, when an application for a permit is submitted to construct four new units on the same parcel, one of the new four units would have to fully comply with the regulations. The remaining three new units, if accessible, must have the 12 mandatory features.]

Application of the Regulations - Mandatory Features

Applicable Code Sections: 110A(b)9 - [Formerly Section 2.110(b)9]. *To determine the total number of dwelling units affected by these regulations, the total number of apartment houses on a building site shall be considered as one building.*

The access and adaptability requirements shall apply to not less than the following number of apartment house dwelling units on a building site:

5 through 20 – one unit

21 and over - one unit, plus one for each additional 20 units or fractional portion thereof

All other apartment dwelling units on primary entrance floors and other floors above or below the primary entrance floor served by ramp, elevator or special lift shall be made to comply with the following requirements:

- A. Grab bar backing [Sections 511.1 (a)9 and 1214.1 (d)5, Exception];*
- B. 32-inch clear door and interior opening width [Sections 1214.1(a)2, 3304(i.1)2B, 3304(i.1)2C, 3304(m)2, and 3304(n)];*
- C. Lever hardware [Section 3304(c)4];*
- D. Door buzzer, bell or chime [Section 1214.1(b)5];*
- E. 18-inch clear space by door [Sections 1214.1(d)1 and 3304(i)2B];*
- F. Minimum 15-inch water closet seat height [Section 1214.1(d)5, Exception 4]*
- G. Electrical receptacle outlet height [Section 210-50(e)];*
- H. Light switch height [Section 380-8(c)];*
- I. Faucet Controls [Sections 1504(c)];*
- J. Water closet, bathtub, and lavatory minimum space requirements are applicable to one bathroom only in apartment house dwelling units containing multiple bathrooms [Sections 511.1(b)1A, 1214.1(d)3, 1214.1(d)4 and 5-1504(a), Exception];*
- K. Path of travel from parking facility to dwelling unit [Sections 417, 3325(a), 3325(b) without Exception 1, 3326(a) and (b)];*
- L. Effective July 1, 1990, base cabinets directly under kitchen sink counter area, including toeboard and shelving, shall be removable to provide clearance for a wheelchair. Finished flooring shall be as specified in Section 1214.1(b)3.*

Note 1: *Path of Travel as used in this section shall not be construed as requiring the installation of an elevator or special chair lift; however, when an elevator serves a parking level and one or more levels containing dwelling units, the elevator entrance shall be accessible to the disabled community. (See definition on Page 10.)*

Note 2: *Path of travel as used in this section shall apply to walks, sidewalks, and ramps serving ground floor primary entrances to dwelling units having a total occupant load of 30 or less.*

Instructor's Note: See Page 10 for definition of Path of Travel.

Exceptions (refers only to accessible units other than the units required to be in full compliance with the regulations):

- 1. When a primary entrance being served is located more than 30 inches above grade.*
- 2. When a path of travel would be located on a slope of greater than 15 percent natural grade.*
- 3. When site constraints do not permit adequate space to allow for the installation, if necessary, of a 1:12 ramp.*

Circulation Components of the Regulations

Instructor's Note: The intent of this section is to clearly describe the regulations designed to open up all areas of the site where a tenant is likely to go, from sidewalk to bedroom. A tenant, whether disabled or non-disabled, will want an open option to participate in any function that is held, whether in the community kitchen, an outdoor seating area, or indoor activity center. Additionally, there is the expectation by all tenants to put trash in the garbage chute, check for mail, pay bills in the manager's office, and use a public laundry room where it exists. If community areas are in the same building as residential occupancies, they are within the scope of the HCD regulations. If community areas are located in a separate building, there are within the scope of regulations of the State Architect.

Accessibility

Applicable Code Section 1214.1(b) [Formerly Section 2-1213(b)] - Living Accommodations. All publicly funded living accommodations, as defined, on accessible floors and primary entrance floors constructed or approved for construction after the effective date of these regulations, shall comply with the following provisions: *Note: Also applies to privately funded apartment houses and buildings and structures used in part for five or more apartments*

Instructor's Note: These regulations apply to privately funded apartment houses. It is important to note that these provisions apply where an application for a building permit has been submitted after the effective date of these regulations.

EXCEPTION 5. In privately funded apartment houses, when all entrances are above or below grade and the floor of the first dwelling unit nearest to grade of living accommodations consisting of five or more units per building, is effectively a story above or below grade, the provisions of this section need not apply unless such dwelling unit is accessible by means of an elevator, ramp, or lift to and from an entrance.

Instructor's Note: When the entrance to an apartment is above or below grade, it is exempt from the provisions of these standards. The 1988 Uniform Building Code states that a story above grade is six feet above grade, and a story below grade is four feet below grade. Grade is considered the lowest point within five feet of the structure, or at the property line, whichever is closer.

Exhibit 2.

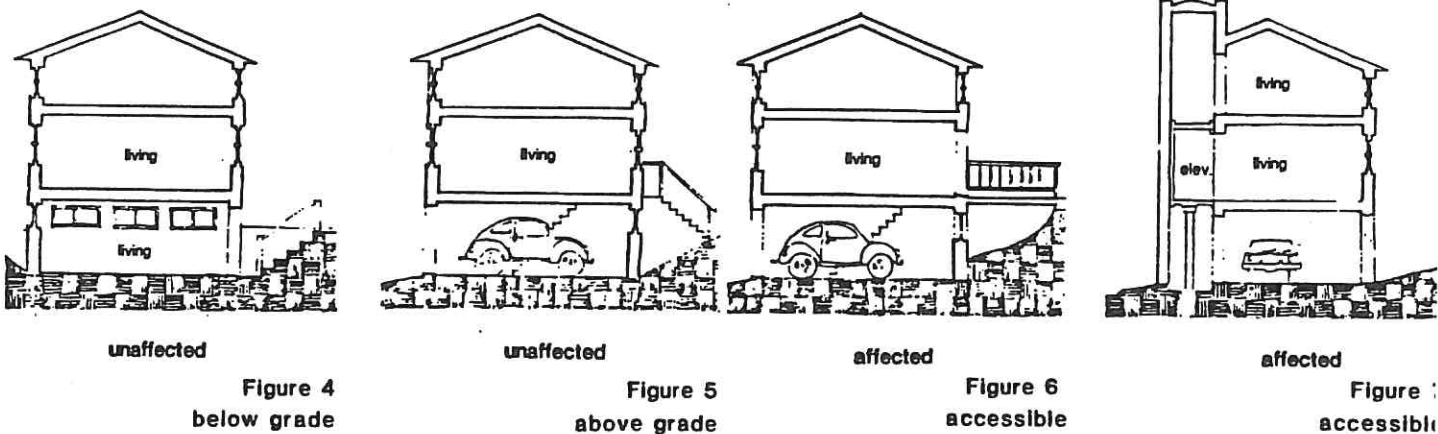

Instructor's Note: While the grade of a site may exempt an apartment building from these standards, those wishing to make their units accessible can take steps to ensure that site development is shaped to minimize exclusion of any tenants. Grading to reduce slope at entry points may require more earth moving, but it can result in fewer stairs or shorter ramps, so the costs of grading may be offset. Privacy from the street may be achieved through design which includes higher windows rather than a higher first floor elevation. Ramps can be made shorter if built against a gradient and concrete landings can be designed economically so they serve two or more units at once.

Parking

Applicable Code Section 1214(b)1. *Parking spaces shall comply with Section 7102 of this Code.*

EXCEPTION: *The requirements for parking spaces contained in Section 7102 do not apply to newly constructed, privately owned apartment houses.*

Instructor's Note: HCD and Office of the State Architect regulations do not apply to privately funded apartment units. If a local jurisdiction wants to regulate parking for privately-funded apartment units, it must do so through a locally adopted ordinance.

Path of Travel

Applicable Code Section 417(d) *defines PATH OF TRAVEL as a passage that may consist of walks and sidewalks, curb ramps, and pedestrian ramps, lobbies and corridors, elevators, other improved areas, or a necessary combination thereof, that provides free and unobstructed access to and egress from a particular area or location, for pedestrians and/or wheelchair users.*

Instructor's Note: Refer to Page 8 for application of path of travel provisions.

Walks and Sidewalks

Applicable Code Section 3325(a). *Walks and sidewalks subject to these regulations shall have a continuous common surface, not interrupted by steps or by abrupt changes in level exceeding 1/2 inch (see c below) and shall be a minimum of 48 inches in width. Surfaces shall be slip-resistant as follows:*

- 1. Slopes less than 6 percent - Surfaces with a slope of less than 6 percent gradient shall be at least as slip resistant as that described as a medium salted finish.*
- 2. Slopes of 6 percent or greater - Surfaces of 6 percent gradient or greater shall be slip-resistant.*
- 3. Surface cross slopes - Surface cross slopes shall not exceed 1/4 inch per foot except when the enforcing agency finds that due to local conditions it creates an unreasonable hardship, the cross slope shall be increased to a maximum of 1/2 inch per foot for distances not to exceed 20 feet.*

EXCEPTION 1: *When because of right of way restrictions, natural barriers, or other existing conditions, the enforcing agency determines that compliance with the 48 inches, clear sidewalk width would create an unreasonable hardship, the clear width may be reduced to 36 inches.*

Instructor's Note: An abrupt change in elevation, or an obstacle protruding into the walk can be an insurmountable barrier for the disabled. Also, curb cuts or ramps shall be provided from privately funded apartment house parking spaces to all adjacent walks or sidewalks. Curb cuts with a slope greater than 1:12 shall be required to provide ramps. Ramps shall comply with Section 7103(b) through 7103(h). Refer to figures in Chapter 71.

Exhibit 3.

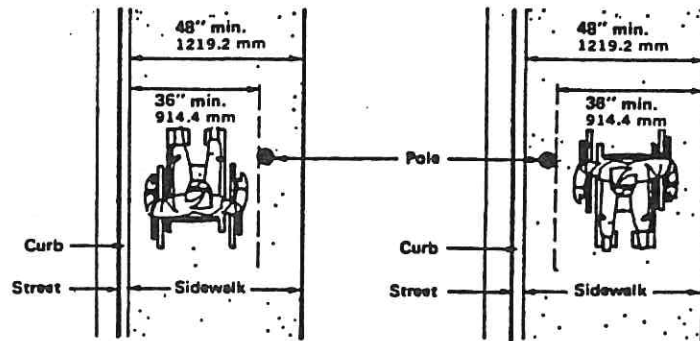

NOTE: In privately funded apartment house complexes, walks and sidewalks serving individual dwelling units may be reduced to 36 inches.

Gratings

Applicable Code Section 3325(b). Walks, sidewalks, and pedestrian ways shall be free of gratings whenever possible. For gratings located in the surface of any of these areas, grid openings in gratings shall be limited to 1/2 inch in the direction of traffic flow.

EXCEPTION 1: Where the enforcing agency determines that compliance with this section would create an unreasonable hardship an exception may be granted when equivalent facilitation is provided.

EXCEPTION 2: This section shall not apply in those conditions where due to legal or physical constraints the site of the project will not allow compliance with these Building Standards or equivalent facilitation without creating an unreasonable hardship. See Section 110A(b)11.D

Five-percent Gradient

Applicable Code Section 3325(c). When the slope in the direction of travel of any walk exceeds 5%, it must comply with the provisions of pedestrian ramps.

Changes in Level

Applicable Code Section 3325(d). Abrupt changes in level along any accessible route shall not exceed 1/2 inch. When changes in level do occur, they shall be beveled with a slope no greater than 1:2 except that level changes not exceeding 1/4 inch can be vertical. Greater level changes are to be beveled with a slope of no more than 50%.

Level Area

Applicable Code Section 3325(e). Walks shall be provided with a level area not less than 60 inches x 60 inches at a door or gate that swings toward the walk, and not less than 48 inches wide by 44 inches deep at a door or gate that swings away from the walk. Such walks shall extend 24 inches to the side of the strike edge of a door or gate that swings toward the walk.

Walks with Continuous Gradients

Applicable Code Section 3325(f). All walks with continuous gradients shall have level areas at least 5 feet in length at intervals of at least every 400 feet.

Warning Curbs

Applicable Code Section 3326(a). Abrupt changes in level, except between a walk or sidewalk and an adjacent street or driveway, exceeding 4 inches in a vertical dimension, such as planters or fountains located in or adjacent to walks, sidewalks, or other pedestrian ways, shall be identified by curbs projecting at least 6 inches in height above the walk or sidewalk surface to warn the blind of a potential drop off.

Exhibit 4.

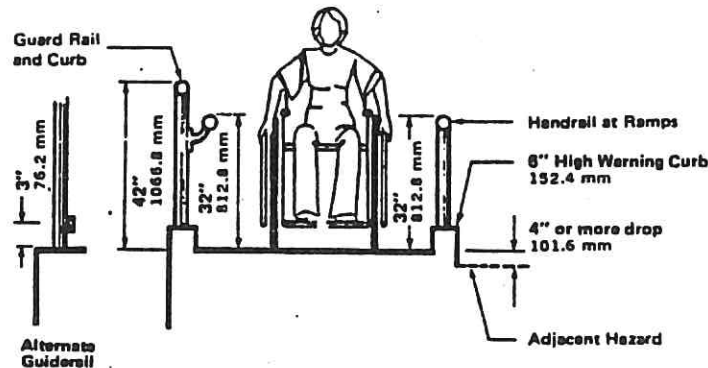

Overhanging Obstructions

Applicable Code Section 3326(b). Any obstruction that overhangs a pedestrian's way shall be a minimum of 80 inches above the walking surface as measured from the bottom of the obstruction.

Primary Entrances

Applicable Code section 3301(f). All primary entrances to buildings and facilities shall be made accessible to the physically disabled.

Temporary Restrictions

Applicable Code Section 3301(f)2. During periods of partial or restricted use of a building or facility, the entrances used for primary access shall be accessible to and usable by the physically handicapped.

Door Buzzers

Applicable Code Section 1214.1(b)5. *Every primary entrance and individual living accommodation shall be provided with a door buzzer, bell, chime, or equivalent installation.*

EXCEPTION. *In privately funded apartment houses, every primary entrance and individual living accommodations shall be provided with a door buzzer, bell, chime, or equivalent installation connected to permanent wiring.*

Entry Width

Applicable Code Section 1214(a)2. *Every entry, opening, or passage door opening into any area shall have a minimum clear and unobstructed opening of 32 inches with the door positioned at an angle at 90 degrees from its closed position.*

Recessed Doormats

Applicable Code Section 3301(f)3. *Recessed doormats shall be adequately anchored to prevent interference with wheelchair traffic.*

Thresholds

Applicable Code Sections 3304(i)1.A. [Formerly Section 2-3304(i)1.B]. *The floor or landing shall not be more than 1/2 inch lower than the threshold of the doorway.*

EXCEPTION: *Section 3304(i)1A shall not be enforced retroactively.*

Applicable Code Section 3304(i)1B. *Change in level between 1/4 inch and 1/2 inch shall be beveled with a slope no greater than 1:2. Change in level greater than 1/2 inch shall be accomplished by means of a ramp.*

EXCEPTION: *In privately-funded apartment houses, all accessible entrances may have a 1-inch threshold when a 1:3 minimum bevel is provided. Change in level greater than 1 inch shall be accomplished by means of a ramp.*

Exhibit 5.

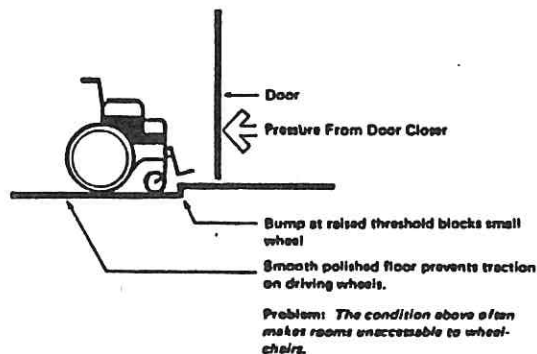

Instructor's Note: Thresholds should be designed to minimize elevation change. Most wheelchair users have difficulty with any more than a 1/4" elevation change, and only the athletic can get over a 1/2" change. Sliding doors need to be thought out carefully because of the deep bottom track.

Floor Level at Doors

Applicable Code Sections 3304(i)1. *Regardless of the occupant load, there shall be a floor or landing on each side of a door.*

Level Floor or Landing

Applicable Code Section 3304(i)2.A *There shall be a level and clear area on each side of an exit door and 44 inches where the door swings away from the level and clear area. The level area shall have a length of at least 60 inches in the direction of door swing as measured at right angles to the plane of the door in its closed position.*

EXCEPTION 1. *In Group R, Division 3 Occupancies and within individual units of Group R, Division 1 Occupancies, a door may open on the top step of a flight of stairs or an exterior landing, provided the door does not swing over the top step or exterior landing and the landing is not more than 7 1/2 inches below the floor level.*

Applicable Code Section 3304(i)2B. *The floor or landing on each side of an exit door shall be level. The level area shall have a length of at least 60 inches in the direction away from the level and clear area. The level area shall have a length of at least 60 inches and the length opposite the direction of door swing of 44 inches as measured at right angles to the plane of the door in its closed position.*

Exhibit 6.

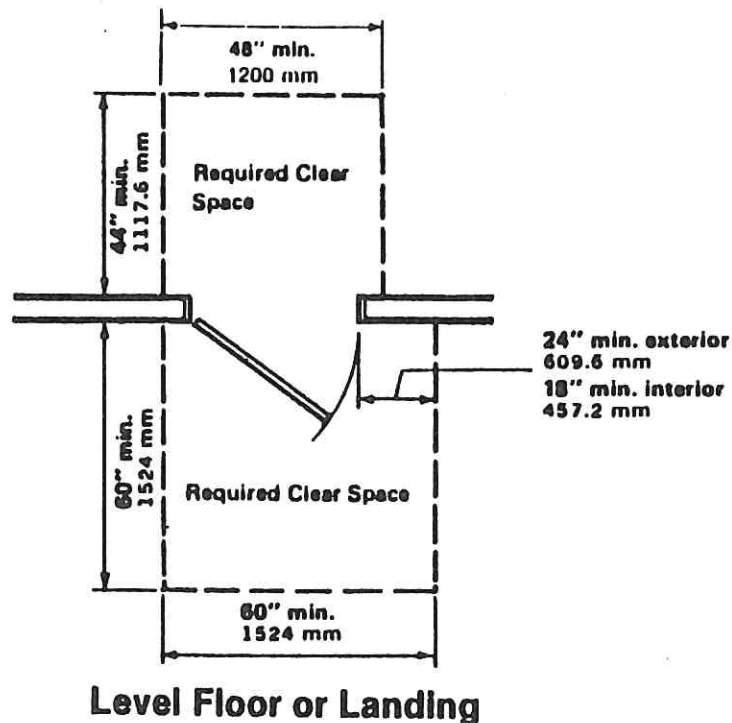

EXCEPTION 1. *In Group R Occupancies, the level area shall have a length both in the direction of door swing and opposite the direction of door swing of 44 inches as measured at right angles to the plane of the door in its closed position.*

EXCEPTION 2. *In privately funded apartment houses the floor or landing, exterior to the apartment house, serving individual dwelling units, shall provide a maximum of 1/4 inch per foot slope in the direction away from the primary entrance of the dwelling unit.*

Instructor's Note: The above exception which permits a maximum 1/4 inch per foot slope away from the primary entrance was added to prevent water accumulation.

Exhibit 7.

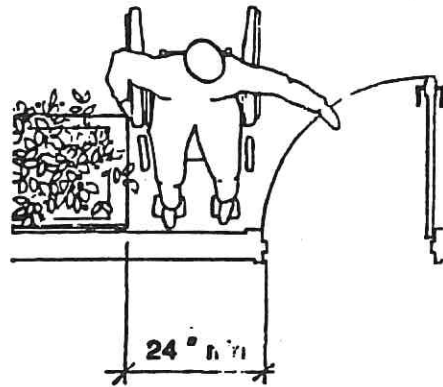

exterior door opening
adjacent space

Adjacent Space

Applicable Code Section 3304(i)2C. *The width of the level area on the side to which the door swings shall extend 24 inches past the strike edge of the door for exterior doors and 18 inches past the strike edge for interior doors.*

Instructor's Note: When taking a position in a wheelchair to open a door, one must let it swing by. Adequate space beside the door is necessary. The exterior door needs 24" alongside the lead edge to ensure that no unplanned obtrusions such as trash cans, parked cars impede the placement of the wheelchair beside the door. The 18" provision applies only to inside the primary entrances to an apartment unit. It is assumed that within the apartment an individual will keep the necessary floor area clear for the narrower front wheelbase (17" s.) for positioning the wheelchair.

Vestibules

Applicable Code Section 3304(i)2D. *The space between two consecutive door openings in a vestibule, serving other than a required exit stairway shall provide a minimum of 48 inches of clear space from any door opening into such vestibule when the door is positioned at an angle of 90 degrees from its closed position. Doors in a series shall swing either in the same direction or away from the space between the doors*

Instructor's Note: In vestibules where doors occur in series, enough room is necessary to pass through one door and take a position to open the next one without worrying about being hit by another person opening the first door again.

Exhibit 8.

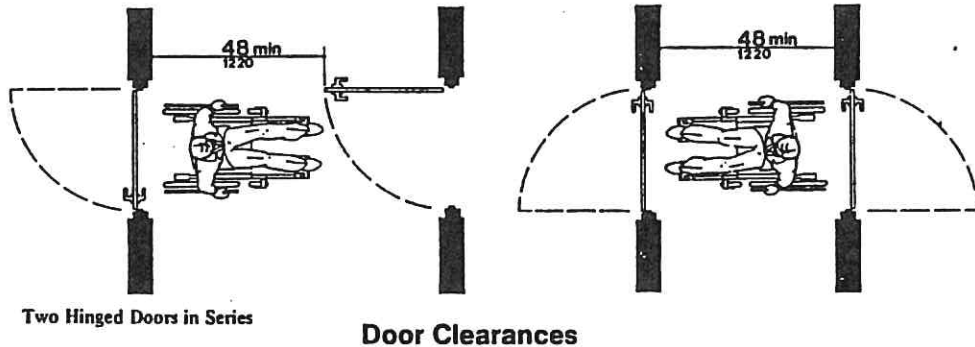

Ramps

General

Applicable Code Section 3307(a). Any path of travel shall be considered a ramp if the slope is greater than 1 foot rise in 20 feet of horizontal run.

Width

Applicable Code Section 3307(b)3. Primary Entrance and Special Occupancy - Pedestrian ramps serving primary entrances to buildings having an occupancy load of 300 or more shall have a minimum clear width of 60 inches. Ramps serving Group R occupancies may be 36 inches clear width when the occupant load is 50 or less. All other pedestrian ramps shall have a minimum width of 48 inches.

Slope

Applicable Code Section 3307(c). The maximum slope of a ramp that serves any exit way, provides handicap access or is in the path of travel shall be 1 foot rise in 12 feet of horizontal run.

Ramp Landings

Applicable Code Section 3307(d). Ramp landings shall be installed as follows:

1. Landings shall be provided at the top and bottom of each ramp. Intermediate landings shall be provided at intervals not exceeding 30 inches of vertical rise and at each change of direction. Landings are not considered in determining the maximum horizontal distance of each ramp.

Size of Top Landing

Applicable Code Section 3307(d)2. Top landings shall be not less than 60 inches wide and shall have a length of not less than 60 inches in the direction of ramp run.

Encroachment of Doors

Applicable Code Section 3307(d)3. *Doors in any position shall not reduce the minimum dimension of the ramp landing to less than 42 inches and shall not reduce the required width by more than 3 1/2 inches when fully opened.*

Strike Edge Extension

Applicable Code Section 3307(d)4. *The width of the landing shall extend 24 inches past the strike edge of any door or gate for exterior ramps and 18 inches past the strike edge for interior ramps.*

Landing Width

Applicable Code Section 3307(d)5. *At bottom and intermediate landings, the width shall be at least the same as required for the ramp.*

Exhibit 9.

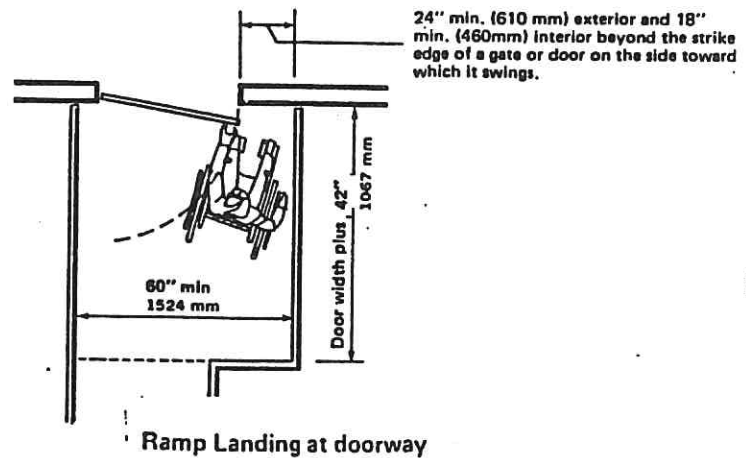

Change of Direction

Applicable Code Section 3307(d)6. *Intermediate landings at a change of direction in the direction of ramp run of not less than 72 inches.*

Other Intermediate Landings

Applicable Code Section 3307(d)7. *Other intermediate landings shall have a dimension in the direction of ramp run not less than 60 inches.*

Instructor's Note: When ramps are used, the upper landing should be designed large enough to allow a person in a wheelchair to get to the top of the ramp, catch his breath, and take a position to open a door. If the door opens out to the landing, a person should be allowed enough room to be on the landing even if another person opens the door out at the same time. When a door opens away from the landing, enough room should be allowed for a person in a wheelchair to turn around and close the door behind him on the way out.

Exhibit 10.

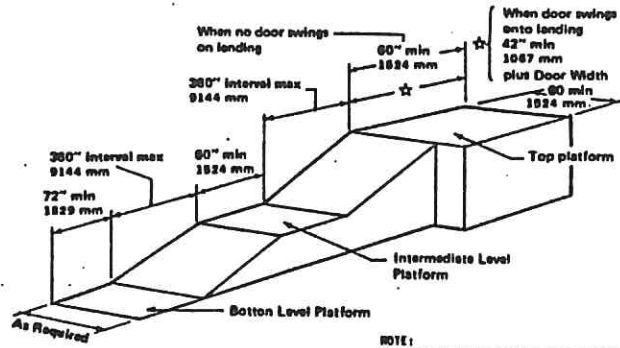

Straight Ramp Run

NOTE:
Maximum Horizontal Distances of each ramp and run varies. See table under 2-3306

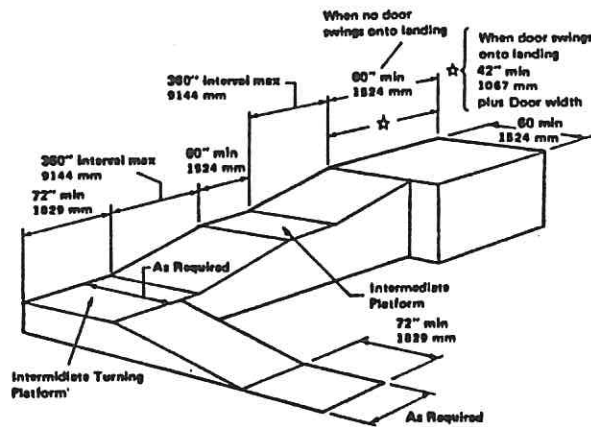

Ramp With Turning Platform

NOTE:
Maximum Horizontal Distances of each ramp and run varies. See table under 2-3306

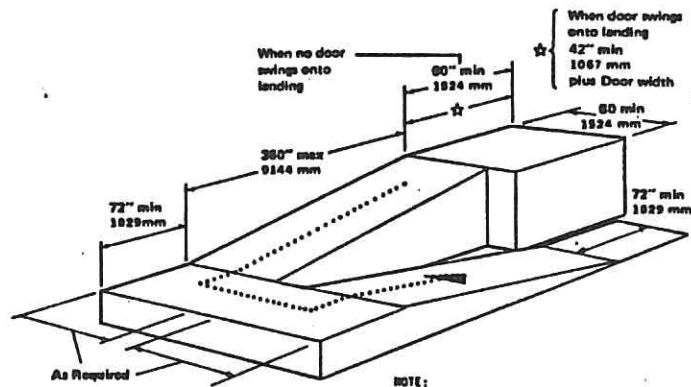

Ramp With Intermediate Switch-Back Platform

NOTE:
Maximum Horizontal Distances of each ramp and run varies. See table under 2-3306

All ramps must meet handrail and curb requirements

Stairways

Treads, Nosings, and Risers

Applicable Code Section 3306(s)1. 1. Treads

- A. All treads surfaces shall be slip-resistant.
- B. Treads shall have smooth, rounded or chamfered exposed edges and no abrupt edges at the nosing (lower front edge).
2. Nosing. Nosings shall not project more than 1 1/2 inches past the face of the riser below.
3. Risers. Risers shall be sufficiently solid to prevent the passage of objects larger than 1/4 inch.

Striping for the Visually Impaired

Applicable Code Section 3306(r). The upper approach and the lower tread of each stair shall be marked by a strip of clearly contrasting color at least 2 inches wide placed parallel to and not more than 1 inch from the nose of the step or landing to alert the visually impaired. The strip shall be of a material that is at least as slip-resistant as the other treads of the stair. A painted strip shall be acceptable.

Where stairways occur outside a building, the upper approach and all treads shall be marked by a strip of clearly contrasting color at least 2 inches wide and placed parallel to and not more than 1 inch from the nose of the step or landing to alert the visually impaired. The strip shall be of a material that is at least as slip resistant as other treads of the stair. A painted strip shall be acceptable.

Instructor's Note: The above provision applies to stairways outside the unit, whether they are outside the apartment building, within a corridor, or between floors.

Handrails

Applicable Code Section 3306(j)1. Stairways shall have handrails on each side, and every stairway required to be more than 88 inches in width shall be provided with not less than one intermediate handrail for each 88 inches of required width. Intermediate handrails shall be spaced approximately equal within the entire width of the stairway.

Exception 2: Stairways serving one individual dwelling unit in Group R, Division 1 or 3 occupancies may have one handrail, except that such stairways open on one or both sides shall have handrails provided on the open side or sides.

Exception 3: Private stairways 30 inches or less in height may have handrails on one side only.

Applicable Code Section 3306(j)2. Exception 6. The provisions of subsection 3306(j)1 shall not apply to existing, privately-funded, apartment houses except when otherwise required under conditions applicable to access for the handicapped. Such existing building shall, however, conform to the provisions of section 3305(j), UBC.

Handrail Configuration

Applicable Code Section 3306(j)2.

- A. Handrails shall be 30 inches to 34 inches above the nosing of the treads.
- B. Handrails shall extend a minimum of 12 inches beyond the top nosing and 12 inches plus the tread width beyond the bottom nosing.
- C. Ends shall be returned or shall terminate in newell posts or safety terminals.

D. Where the extension of the handrail in the direction of the stair run would create a hazard, the extension shall be made at right angles, on the face of a returning wall. Where the stairs are continuous from landing to landing, the inner rail shall be continuous and need not extend out into the landing.

E. Handrails projecting from a wall shall have a space of not less than 1 1/2 inches between the wall and the handrail.

F. The handgrip portion of handrails shall be not less than 1 1/4 inches nor more than 2 inches in cross-sectional dimension or in the shape shall provide an equivalent gripping surface and shall have a smooth surface with no sharp corners.

Instructor's Note: The stairway requirements in these standards effectively apply only to public stairways in an apartment building which are used as a public means of egress. However, when such stairways do exist, they should be clearly marked at their upper and lower ends by handrail extensions and safety striping to let someone with poor vision know when they start and stop. The handrail should be detailed to allow firm grip by those who need support.

Corridors

Corridor Widths

Applicable Code Section 3305(b)1. Every corridor serving an occupant load of 10 or more shall be not less in width than 44 inches. Regardless of occupant load, corridors in Group R, Division 3 Occupancies and within the dwelling units in Group R, Division 1 Occupancies shall have a minimum width of 36 inches.

Instructor's Note: For special requirements for Groups R and I occupancies, see Sections 3319, UBC and 3321. Also, a state interpretation is available in the Appendix.

Applicable Code Section 3305(b)2. Corridors over 200 Feet - Corridors which exceed 200 feet in length shall:

- A. Have minimum clear width of 60 inches or;
- B. Have, at a central location, a 60 inches x 60 inches minimum wheelchair turning space or passing alcove, or;
- C. Have, at a central location, an intervening cross or tee corridor, a minimum of 44 inches in width, or;
- D. Have, at a central location, an openable door.

Door Openings

Applicable Code Section 3304(f)1. Every required exit doorway shall be of a size as to permit the installation of a door not less than 3 feet in width and not less than 6 feet, 8 inches in height. When installed in exit doorways, exit doors shall be capable of opening at least 90 degrees and shall be so mounted that a clear width of exit way is not less than 32 inches. In computing the exit width the net dimension of the exit way shall be used.

Exhibit 11.

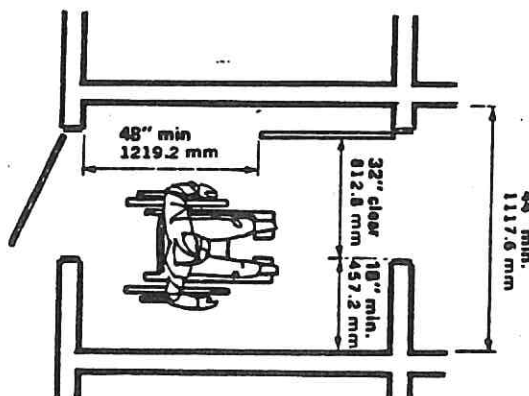

Door Clearances

Instructor's Note: To pass through a door opening in a wheelchair which may be 28" wide without scraping knuckles, door or jamb, the clear width has to be at least 32". This allows two extra inches on each side of the wheelchair, barely adequate, especially when turning 90 degrees from a corridor. Public corridors need to be wide enough for others to pass by and to turn around if desired.

In apartment hallways where traffic patterns are quieter, enough room is needed to pivot the wheelchair through the door opening without scraping the opposite wall.

Hardware

Approval

Applicable Code Section 3304(m)1. *Exit door hardware shall be of an approved type and tested in accordance with the procedures established by the SFM 33.2 and SFM 33.3 as shown in Chapter 60.*

Applicable Code section 3304(m)2. Effort to Operate Doors. *Maximum effort to operate doors shall not exceed 8 1/2 lbs for exterior doors and 5 lbs. for interior doors, such pull or push effort being applied at right angles to hinged doors and at the center plane of sliding or folding doors.*

Compensating devices or automatic door operators may be utilized to meet the above standards. When fire doors are required, the maximum effort to operate the door may be increased not to exceed 15 lbs.

Door Construction

Applicable Code Section 4403(n). *The bottom 10 inches of all doors except automatic and sliding shall have a smooth uninterrupted surface to allow the door to be opened by a wheelchair footrest without creating a trap or hazardous condition. When narrow frame doors are used, a 10 inches high smooth panel shall be installed on the push side of the door, which will allow the door to be opened by a wheelchair footrest without creating a trap or hazardous condition.*

Types of Locks or Latches

Applicable Code Section 3304(c)1. *Exit doors shall be openable from the inside without the use of a key or special knowledge or effort.*

Applicable Code Section 3304(c)4. *Hand activated door opening hardware shall be centered between 30 inches and 44 inches above the floor. Latching and locking doors that are hand activated and which are in the path of travel, shall be operable with a single effort by lever type hardware, by panic bars, push-pull activating bars, or other hardware designed to provide passage without requiring the ability to grasp the opening hardware. Locked exit doors shall operate as above in egress direction. Doors to individual hotel or motel units shall operate similarly, except that when bolt and unlatching operation is key operated from corridor or exterior side of unit door, large bow keys 2 inches full bow or 1 1/4 inches half bow shall be provided in lieu of lever-type hardware on the corridor side. Separate dead lock activation on room side of corridor doors in hotels or motels shall have level handles or large thumb turn in an easily an easily reachable location.*

Applicable Code Section 3304(c)2. *Exit doors from buildings or rooms having an occupant load of 10 or less may be provided with a night latch, dead bolt or security chain, provided such devices are openable from the inside without the use of a key, special knowledge or effort and mounted at a height not to exceed 48 inches above the finished floor.*

Height Components of the Regulations

Instructor's Note: To be accessible to a disabled person whose upper reach may be limited, careful consideration must be taken to assure that a correct thermostat setting can be made, switches and electrical receptacles can be reached, and storage can be used.

Receptacle Outlets Required

Applicable Code Section 3-210-50(e) - Installation Height. *The center of 15, 20 and 30 ampere receptacle outlets required by Section 210-25 (a), (b), and (c) shall be installed not less than 12 inches above the floor or working platform.*

Exceptions:

1. Receptacle outlets installed as a part of permanently installed baseboard heaters are exempt.
2. Required receptacle outlets shall be permitted in floors when adjacent to sliding panels or walls.
3. Baseboard electrical outlets used in relocatable partitions, window walls or other electrical convenience floor outlets are not subject to the minimum height requirements.

Switches

Applicable Code Section 3-380-8(c). *The center of the grip of the operating handle of switches intended to be used by the occupant of the room or area to control lighting and receptacle outlets, appliances, or cooling, heating, and ventilating equipment shall be not less than 3 feet nor more than 4 feet above the floor or working platform.*

Lower Shelving

Applicable Code Section 1214(b)4. *Lower shelving and/or drawer space shall be provided in the kitchen at a height of no more than 48 inches.*

Exhibit 12.

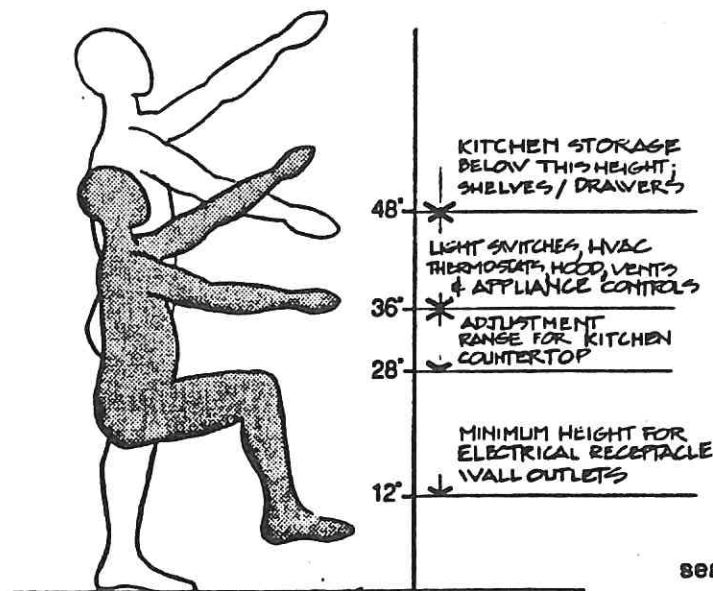

seated and standing range of motion

Bathroom Components of the Regulations

Instructor's Note: A bathroom's fixtures - sink, toilet, and tub or shower - are points of activity which need correct height, width, and clear floor space in order to be comfortably used.

Whether disabled or non-disabled, a person wants to wash his or her face without getting everything else wet, to comb hair in the mirror, to get onto a toilet without bumping against a side wall or falling too quickly onto the seat, to get safely into a tub to take a bath or shower, and to dry off outside.

A person using a wheelchair needs a 30" x 48" rectangle to maneuver for transfer to the toilet or into the bathtub. If a person in a wheelchair does not have space to position for that transfer, there is an increased chance the user will fall.

The 30" x 48" rectangle can overlap other spaces. Making a bathroom large will not necessarily improve it. The placement of a lavatory next to the tub does not impede wheelchair movement if the bottom of the front lip is high enough (27 inches) to allow knee movement beneath it.

Exhibit 13.

The Accessible Bathroom: Design considerations for compliance using a minimum of floor space area.*

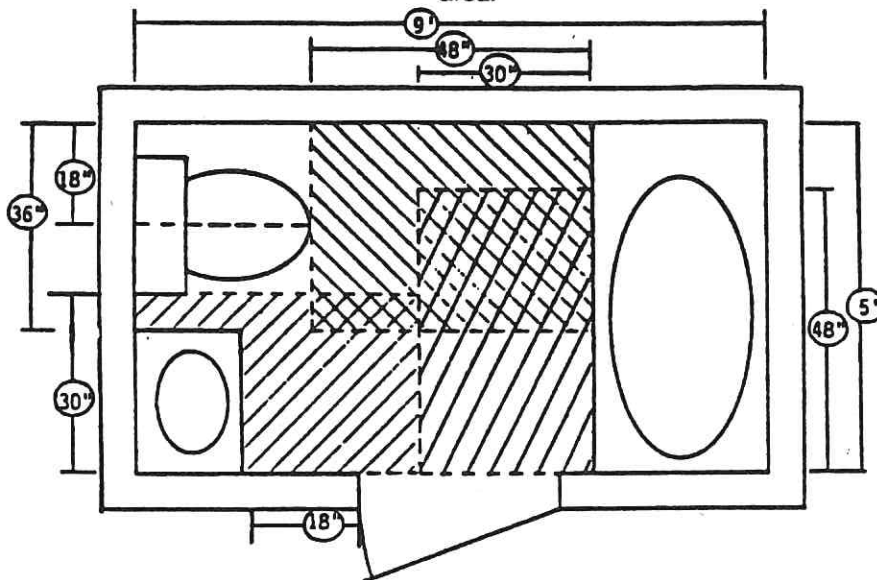

Bathroom Entrance Doorways

Applicable Code Section 1214(d)1. Bathroom entrance doorways shall have at least an 18 inch clear space to the strike edge of the door on the swing side of the door.

Interior Surfaces

Applicable Code Section 511(a)10. *In other than dwelling units, toilet room floors shall have a smooth, hard, non-absorbent surface such as portland cement, concrete, ceramic tile, or other approved material which extends upward onto the walls at least 5 inches. Walls within water closet compartments and walls within 24 inches in front and sides of urinals shall be similarly finished to a height of 48 inches and, except for structural elements, the materials used in such walls shall be of a type which is not adversely affected by moisture.*

Water closets

Applicable Code Section 1214(d)4. *The water closet shall conform to the provisions of Section 5-1502 (Part 5 of Title 24). The water closet may be located in a space 36 inches in clear width with 48 inches of clear space provided in front of the water closet. This space may include maneuverable space under a lavatory arranged so as not to impede access. Doors shall not infringe on above clearances.*

In privately funded apartment houses, a clear space of 36" by 48" shall be provided in front of the water closet. The 48" dimension may be parallel or perpendicular to the center line of the toilet.

Applicable Code Section 1214(d) EXCEPTION 4. *In living accommodations, water closets need not conform to the minimum or maximum height requirements provided such water closets are so designed and arranged so as to be adaptable to a height of not less than 15 inches measured to the top of the seat.*

Instructor's Note: Water closet, bathtub and lavatory minimum space requirements are applicable to one bathroom only in apartment house dwelling units containing multiple bathrooms.

Transfer Types

Instructor's Note: Three transfers are shown from a wheelchair onto a toilet seat (Figures 31, 32, 33). The maneuvering space around a toilet cannot be overemphasized. Because of the number of possible transfers, sufficient space is required for a toilet to be accessible for a person with disabilities.

Exhibit 14.

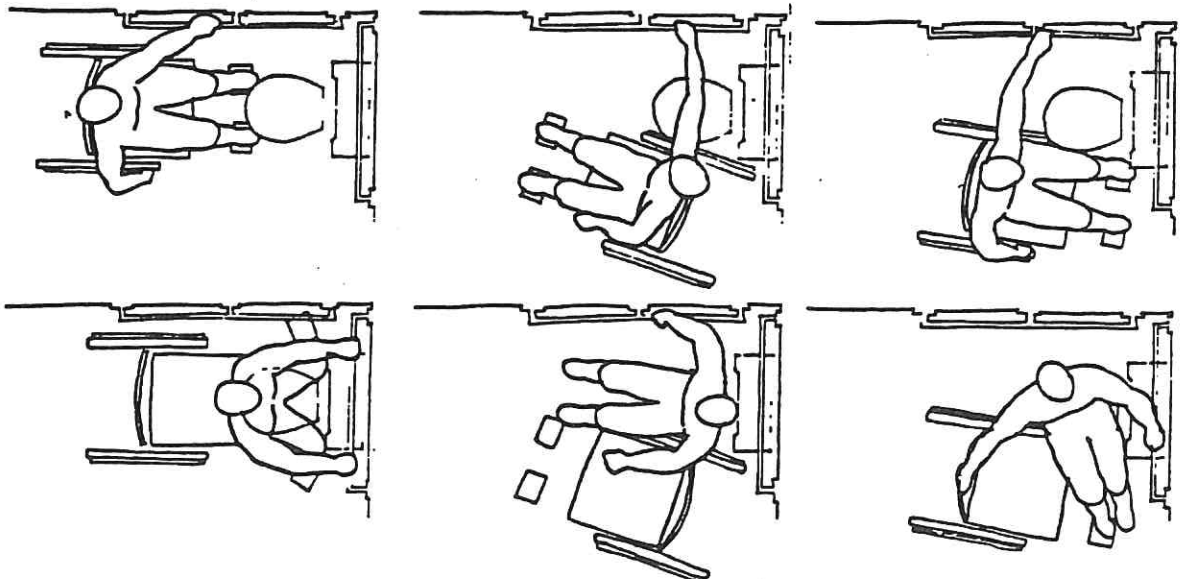

Figure 31
type 1

Figure 32
type 2

Figure 33
type 3

Lavatory

Applicable Code Section 511(b)1.A. *A clear space 30 inches by 48 inches complying with Section 522(c), shall be provided in front of a lavatory to allow a forward approach. Such clear floor space shall adjoin or overlap an accessible route and shall extend into knee and toe space underneath the lavatory.*

Instructor's Note: The lavatory must be at least 17 inches to the front edge to accommodate a seated person who wants to face directly ahead without splashing water into the lap. Although not a requirement, the mirror will only be useful to a seated person if its lowest edge is no higher than 40 inches.

Applicable Code Section 5-1504(a). *Lavatories shall be mounted with a clearance of at least 29 inches from the floor to the bottom of the apron with knee clearance under the front lip extending a minimum of 30 inches in width with 8 inches minimum depth at the top. Toe clearance shall be the same width and shall be a minimum of 9 inches high from the floor and a minimum of 17 inches deep from the front of the lavatory.*

Applicable Code section 5-1504(a) EXCEPTION. *In privately funded apartment houses the space under the lavatory may be omitted provided the door swing does not encroach on clear space in front of the lavatory, water closet and bathtub-shower in the accessible bathroom.*

Applicable Code Section 5-1504(b). *Hot water and drain pipes under lavatories shall be insulated or otherwise covered. There shall be no sharp or abrasive surfaces under lavatories.*

Applicable Code Section 5-1504(c). *Faucet controls and operating mechanisms shall be operable with one hand and shall not require tight grasping, pinching or twisting of the wrist. The force required to activate controls shall be not greater than 5 lbs. Lever-operated, push-type and electronically controlled mechanisms are examples of acceptable designs. Self-closing valves are allowed if the faucet remains open at least 10 seconds.*

Exhibit 15.

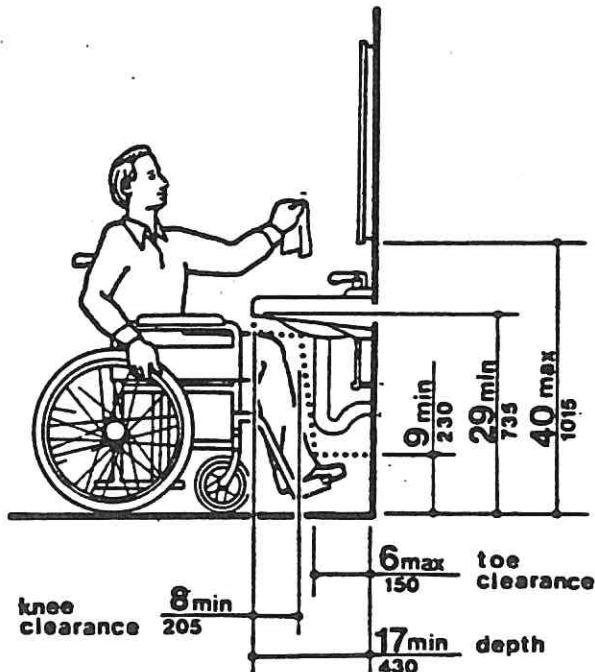

Grab Bars

Applicable Code Section 511(a)8A. *Grab bars located on each side, or one side of the back of the physically handicapped toilet stall or compartment, shall be securely attached 33 inches above and parallel to the floor. Grab bars at the side shall be at least 42 inches long with the front end positioned 24 inches in front of the water closet stool, and grab bars at the back shall be not less than 36 inches long.*

Applicable Code Section 1214(d) EXCEPTION 5. *Living accommodations need not provide grab bars provided backing is installed to allow future installation of grab bars.*

Exhibit 16.

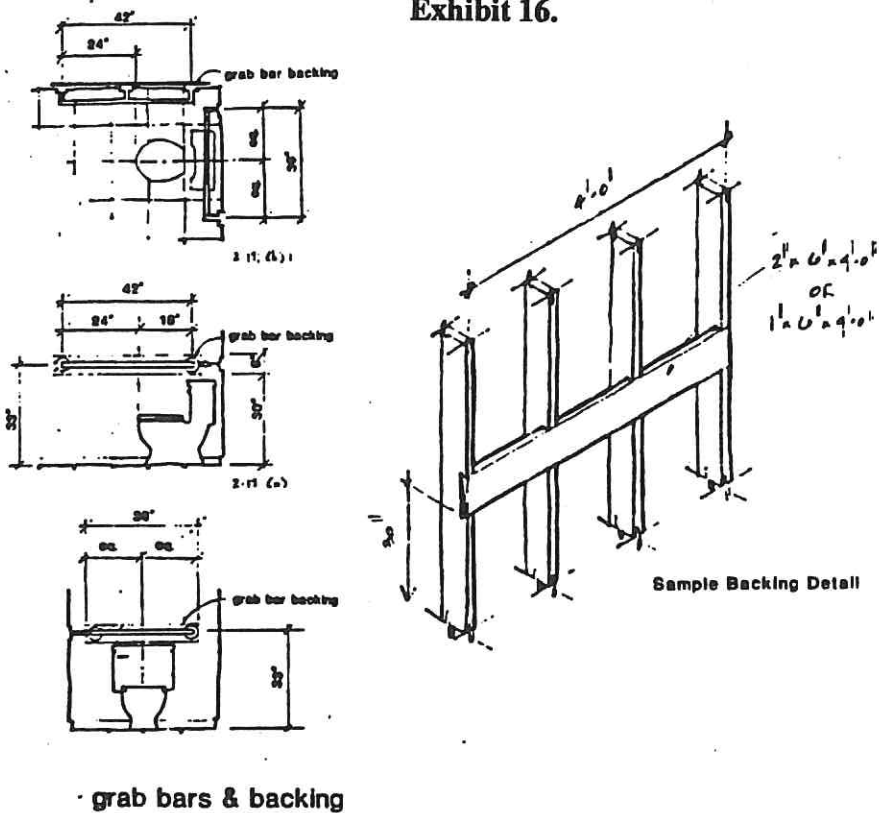

Diameter or Width

Applicable Code section 511(a)8B. *The diameter or width of the gripping surface of a grab bar shall be 1 1/4 inch to 1 1/2 inch or the shape shall provide an equivalent gripping surface. If grab bars are mounted adjacent to a wall, the space between the wall and the grab bars shall be 1.5 inches.*

Structural Strength

Applicable Code Section 511(a)c. *The structural strength of grab bars, tub and shower seats, fasteners, and mounting devices shall meet the following specifications:*

(1) Bending stress in a grab bar or seat induced by the maximum bending movement from the application of 250 pounds per foot shall be less than the allowable stress for materials of the grab bar or seat.

(2) Shear stress induced in a grab bar or seat by the application of 250 lbs per foot shall be less than the allowable shear stress for the material of the grab bar or seat, and its mounting bracket or other support is considered to be fully restrained, then direct and torsional shear stresses shall not exceed the allowable shear stress.

(3) Shear force induced in a fastener or mounting device from the application of 250 lbs. per foot shall be less than the allowable lateral load of either the fastener or mounting device or the supporting structure whichever is the smaller allowable load.

(4) Tensile force induced in a fastener by a direct tension force of 250 lbs. per foot plus the maximum moment from the application of 250 lbs per foot shall be less than the allowable withdrawal load between the fastener and sporting structure.

(5) Grab bars shall not rotate within their fittings.

Surface

Applicable Code Section 511(a)8D. A grab bar and any wall or other surface adjacent to it shall be free of any sharp or abrasive elements. Edges shall have a minimum radius of 1/8 inch.

Instructor's Note: Grab-bar backing let into studs around the toilet allows for future installation, as needed, at virtually no additional cost. By giving a useful height range in which to set future grab-bars, this length of backing will help reduce the number one cause of household injury to elderly people, a fall in the bathroom.

Shower Areas

Applicable Code Section 511(a)11. Shower in all occupancies shall be finished as specified in subsection 511(a)10 to a height of not less than 70 inches above the drain inlet. Materials other than structural elements used in walls shall be of a type which is not adversely affected by moisture.

Doors and Panels

Applicable Code Section 511(a)12. Doors and panels of shower and bathtub enclosures shall be substantially constructed from approved shatter-resistant materials. Hinged shower doors shall open outward.

Glazing

Applicable Code Section 511(a)13. Glazing used in doors and panels of shower and bathtub enclosures shall be fully tempered, laminated safety glass, or approved plastic. When glass is used, it shall have a minimum thickness of not less than 1/8 inch when fully tempered, or 1/4 inch when laminated, and shall pass the test requirements of UBC Standard 54-2.

Plastics

Applicable Code Section 511(a)14. Plastics used in doors and panels of showers and bathtub enclosures shall be of the shatter-resistant type.

Compartment Showers

Applicable Code Section 511(a)9.A. *Compartment showers shall comply to the following requirements:*

1. *Compartment showers shall be 42 inches in width between wall surfaces and 48 inches in depth with an entrance opening width of 36 inches. Grab bars shall comply with subsection 511(a)8.*
2. *When a threshold or recessed drop is used, it shall be a maximum of 1/2 inch in height and shall be beveled or sloped at an angle not exceeding 45 degrees (100% gradient) from the horizontal.*
3. *The shower floor shall slope forward toward the rear to a drain located within 6 inches of a rear wall. Maximum slope of the floor shall be 1/2 inch per foot in any direction. The floor surfaces shall be of Carborundum or grit-faced tile or of material providing equivalent slip-resistance.*
4. *Shower accessories shall include: (a) a folding seat located on the wall opposite controls and mounted 18 inches above the bathroom floor.*

Applicable Code Section 1214(d) EXCEPTION 2. *Living accommodations need not provide folding shower seats in shower compartments provided support backing is installed to provide for future use of an adaptable unit.*

Applicable Code Section 1214(d) EXCEPTION 3. *Living accommodations need not provide a shower spray unit in bathroom.*

Instructor's Note: If a compartment shower is used, it must be large enough to accommodate a person in a wheelchair, with backing provided to allow for the future installation of a seat to transfer into, if desired. The 42" x 48" floor area would give enough extra room to avoid damaging tile or fiberglass walls with the steel edges of the wheelchair. It is important to note that a folding seats is shower compartments are not required provided that proper backing is provided for future installation. Shower spray units, also, are not a requirement.

Exhibit 17.

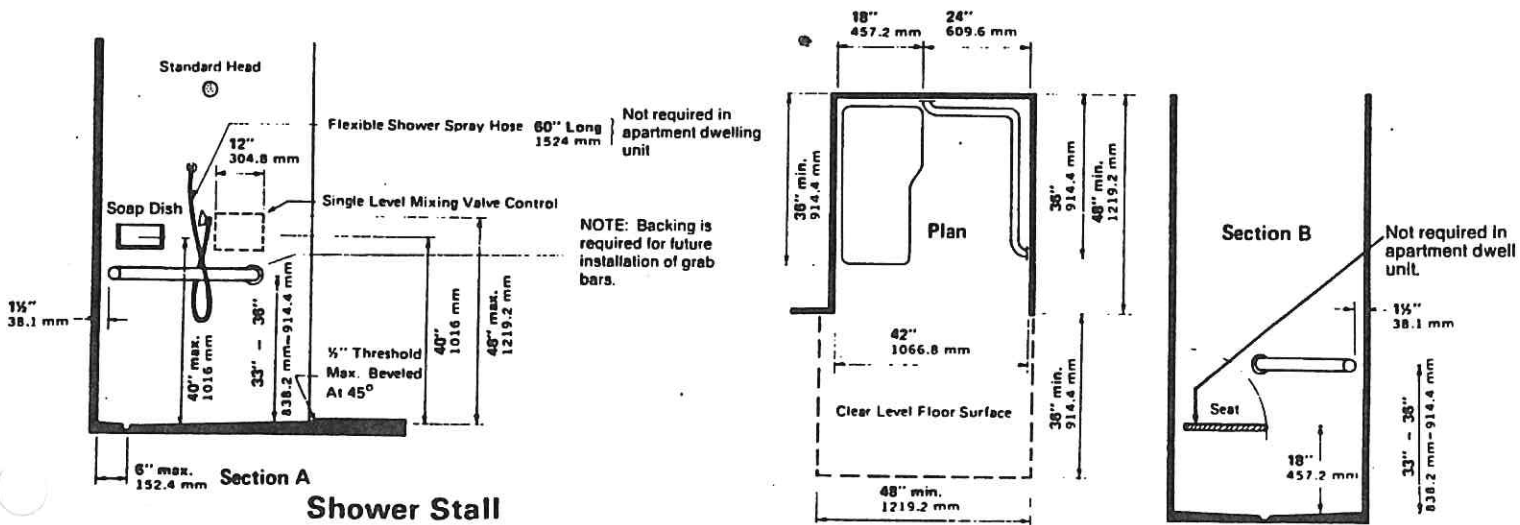

Bathtubs

Applicable Code Section 1214(d)3. *There shall be a minimum space of 48-inch parallel by 30 inch perpendicular to the side of the bathtub or bathtub shower combination to provide for the maneuvering of a wheelchair and transfer to and from the bathing facilities, which may include the maneuverable area under the lavatory.*

Exhibit 18.

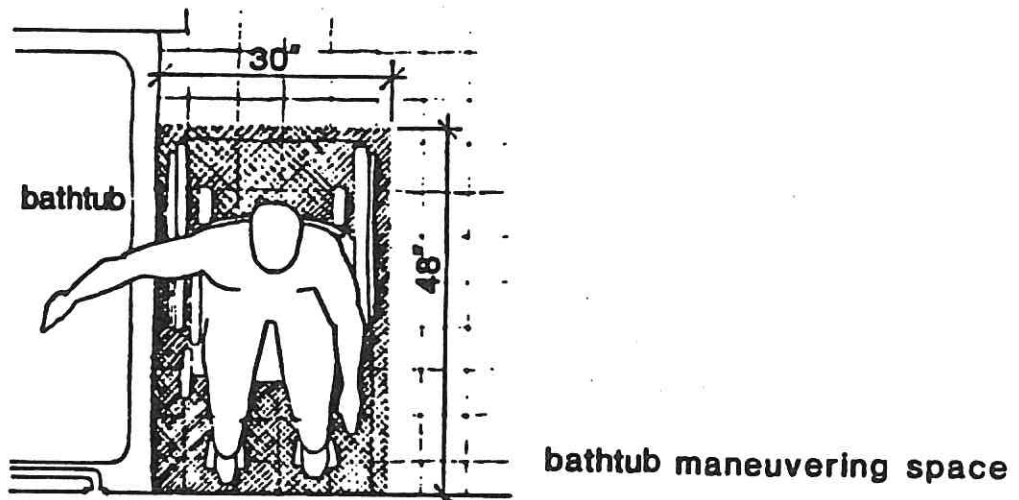

Instructors Note: The clear space beside the tub is important not only for transfer but for adjusting water controls.

Kitchen Components of the Regulations

Instructor's Note: People with disabilities as well as non-disabled persons have certain basic demands for a kitchen - appliances and storage spaces usable and reachable within a comfortable range of motion, adequate flat surfaces for preparation of meals, and quick clean-up of dishes and surrounding counter areas to maintain hygiene.

Designing for such kitchen should be thought out from the perspective of a standing person and one who is seated in a wheelchair. The seated person is lower and has a different center of gravity which makes a low reach more difficult. The wheelchair uses more floor space both at rest and maneuvering to a new position than would a standing or walking person.

A kitchen which is designed to be adaptable for a wide variety of users must provide ground level storage no more than 48 inches in height. Switches for lights, temperature, fan, and appliance controls must be within 36" to 48" in height from the floor. Relative to lowerable counters, there must be adequate adjustment of a work surface and sink area to prepare meals with the elbows lowered, a distance which may vary from 28" to 36". Also, the lowest wall outlets must be no less than 12" above the floor.

Although not required by law, both freezer and refrigerator should allow seeing as well as reaching of contents. Front controls for ranges and low-mounted hood fan switches are helpful. Dishwasher and oven doors which open to the side, also, are easier to use by a seated person. Countertops immediately adjoining wall ovens are convenient for setting heavy pans as they are removed from the oven.

The distance between cabinet face and opposite wall/cabinet face differs from four feet for an L-shaped kitchen to five feet for a U-shaped kitchen because the doors of the base cabinets can be opened by a person in a wheelchair only when they can swing by. It is difficult to efficiently use the space if constant wheelchair repositioning were necessary to get at the storage areas.

Exhibit 19.

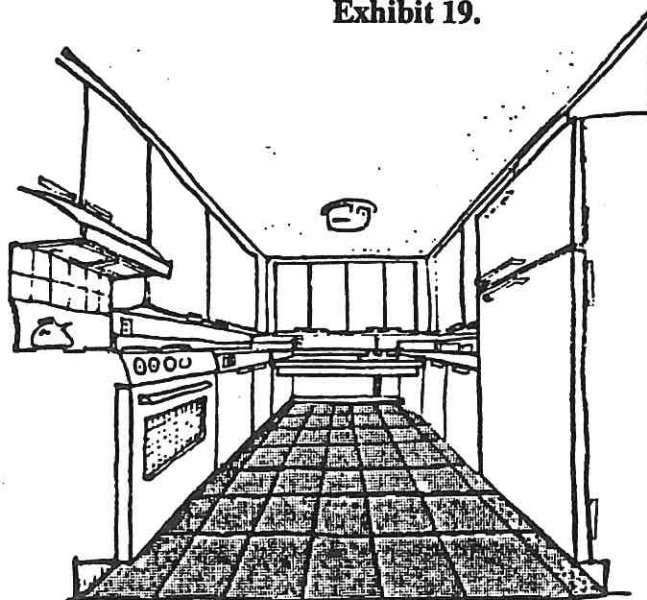

u-shaped perspective

Accessibility in Kitchens

Applicable Code Sections. 1214.1(a)2. *Kitchens shall be designed and constructed to provide a minimum clear space of 60 inches between cabinet fronts, countertops or walls for all u-shaped kitchen areas with a minimum clear space of 48 inches shall be provided for all other kitchen designs.*

EXCEPTION 1. *In privately funded apartment houses, U-shaped kitchens with cabinets, appliances or fixtures on three walls shall be designed and constructed to provide a minimum clear space of 60 inches between cabinet fronts, appliances or fixtures. A minimum clear space of 48 inches shall be provided for all other kitchen designs.*

EXCEPTION 2. *In privately funded apartment houses, the space between cabinets, appliances or fixtures in U-shaped kitchens may be reduced to 48 inches clear space provided cabinet face is removable to a height of 27 inches above the floor to permit the completion of a 60 inch diameter circle centered within 12 inches of the sink center.*

Exhibit 20.

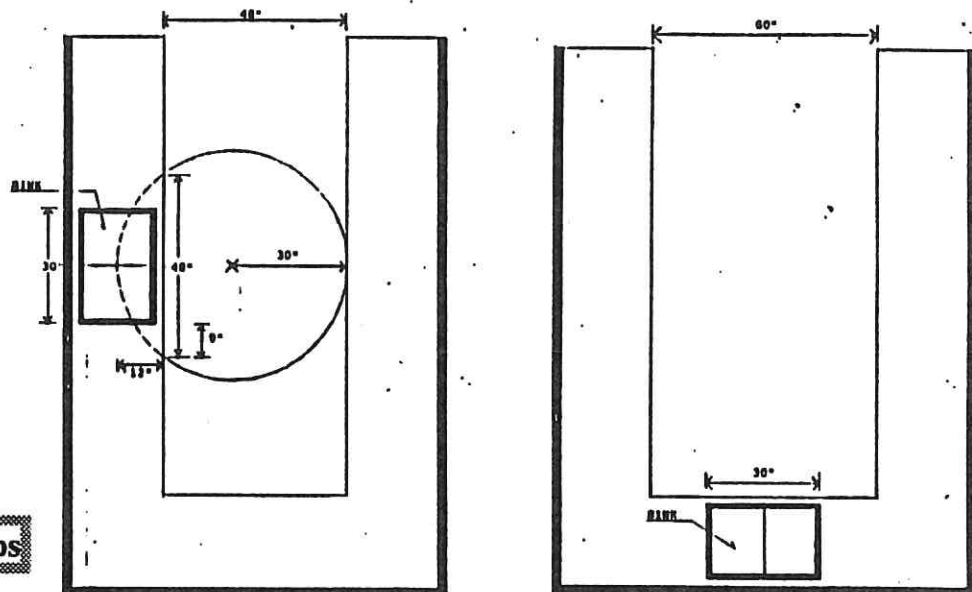

Countertops

Applicable Code Section 1214(b)3. *A minimum linear length of 30 inches of countertop shall be provided for the kitchen sink, and a minimum linear length of 30 inches of countertop shall be provided for a work surface, both of which shall be designed to enable repositioning to a minimum height of 28 inches. The sink and work surface may be a single integral unit, or be separate components. The base cabinets directly under sink and work surface counter areas which are designed for repositioning shall be removable to provide clearance for a wheelchair.*

The sides and back of adjacent cabinets, which may become exposed to moisture or food handling when a countertop is lowered, shall be constructed of durable, nonabsorbent materials appropriate for such uses. Finished flooring shall be installed on the floor beneath such countertop.

NOTE: *Plumbing shall be installed in a manner to permit repositioning of the sink and countertop.*

Instructor's Note: The installation of garbage disposals will not be feasible in an adaptable unit.

EXCEPTION 1. *Stone, cultured stone, and tile countertops may be used without meeting the repositioning requirements.*

EXCEPTION 2. *In privately funded apartment houses, two 15 inch minimum width breadboards may be provided in lieu of the required 30 inches of countertop work surface.*

Instructor's Note: In general, flat surfaces for food preparation and clean-up are designed to a 36 inch standard for a person of average height, but not for a shorter person, or one who is seated. The adjustable countertop for work and sink areas (28" - 36") accommodates a wide range of users. The 2'6" length for each area allows a person in a wheelchair to draw under the counter as if sitting at a desk. Also, the HCD regulations permit installation of two 15 inch minimum width breadboards in lieu of the required 30 inches of counter top work space.

The adjustable area can be constructed like the rest of the countertop, including side and back splash board to control any surface water. One approach is to set the countertop on a 2 x 4 box with a fascia piece and use backing let into the rear and side walls for support. When both work and sink area are combined, an adequate place for drying dishes will be on the same plane as the sink.

Finishing the floor to the wall under these adjustable areas maintains the life of the building longer than attempting to deal with individual changes as they arise.

Exhibit 21.

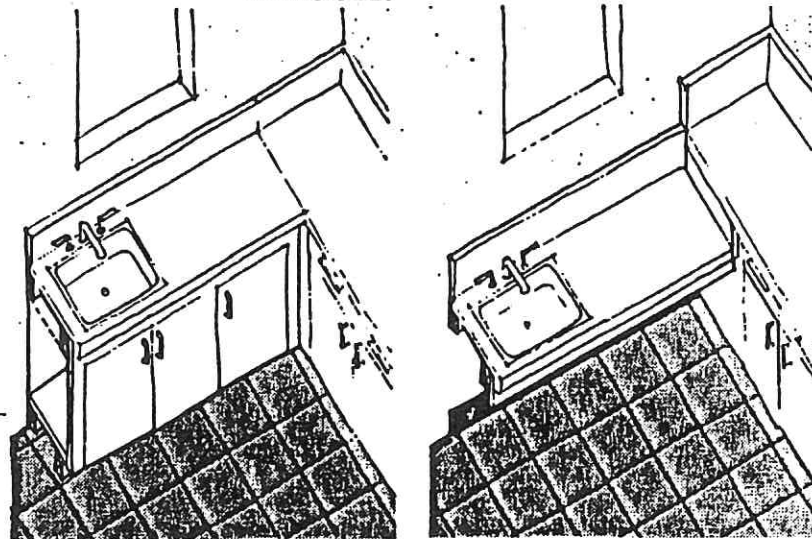

Lower Shelving

Applicable Code Section 1214.1(b)4. *Lower shelving and/or drawer space shall be provided in the kitchen at a height of no more than 48 inches.*

Faucets

Applicable Code Section 5 - 1508 (See Part 5-State Amendments to the Uniform Plumbing Code). *Faucet controls and operating mechanisms shall be operable with one hand and shall not require tight grasping, pinching, or twisting of the wrist. The force required to activate controls shall be no greater than 5 lbs. Lever-operated, push type and electronically controlled mechanisms are examples of acceptable designs. Self-closing valves are allowed if the faucet remains open for at least 10 seconds.*

IV. INFORMATION ON PENDING FEDERAL REGULATIONS

At this point, it is appropriate to briefly discuss what future changes to these regulations we might reasonably expect. Specifically, federal legislation known as the Federal Fair Housing Amendments Act of 1988 was signed into law by President Reagan on September 13, 1988. This Act expands the scope of the Civil Rights Act by prohibiting discriminatory housing practices toward disabled persons and families with children. This legislation established an administrative enforcement mechanism which provides for monetary penalties of up to \$50,000 per infraction. Most importantly, for our purpose here, this federal legislation authorizes the Department of Housing and Urban Development (HUD) to issue design and construction requirements for all new multifamily dwelling units located:

- a) in buildings consisting of 4 or more units if such buildings have one or more elevators; and
- b) on the ground floor in other buildings consisting of 4 or more units.

The regulations issued by HUD must insure that all doors designed to allow passage into and within an applicable dwelling unit are wide enough to allow passage by persons using wheelchairs. In addition, there must be an accessible route into and through the dwelling. The HUD regulations will also require bathrooms and kitchens to be designed in a way which allows a person in a wheelchair to maneuver within those areas. Finally, the public and common use areas must be readily accessible to and usable by disabled persons.

At the time this workbook went to print, HUD was still in the process of developing the construction specifications which establish minimum standards of acceptable design compliance. Also under development is a comprehensive set of application provisions which clearly define when and/or where compliance will be considered impractical due to site and terrain conditions.

With regard to the effective date, the current statutory language requires applicable multifamily dwellings intended for first occupancy on or after March 13, 1991 to comply with the yet to be developed regulations. Recognizing that the statutory language provided a rather unorthodox implementation mechanism, HUD issued a ruling which establishes an exemption for projects which have been issued a final building permit prior to January 13, 1990. Given that the regulations are still under development, HUD may find it necessary to postpone the January 13, 1990 date.

Since less stringent state or local requirements will be superceded by the federal regulations, it would be appropriate to mention the most significant regulatory impacts which California can expect to experience (given present knowledge).

- *The application provision of California's (HCD) accessibility regulations (effective January 1, 1990) require full compliance in at least 5 % of all apartment units. Full compliance with the federal regulations (still under development) will be required in every multi-family dwelling unit in buildings with elevators and in all ground floor units in buildings without elevators.*
- *While townhouse units will remain exempt, HUD's implementation rules presently indicate that federal regulations will apply to condominiums.*
- *At present, HCD exempts apartment buildings having fewer than five dwelling units. The federal language allows exemptions for only those multifamily buildings containing three dwelling units.*

CALBO, with the assistance of the California Building Industry Association and other groups will track the development of the construction specifications. When HUD issues their minimum standards for compliance, HCD will most likely be required to adopt appropriate amendments to the California accessibility standards.

V. TYPICAL QUESTIONS AND ANSWERS

1. Has the "cost cap" been repealed?

Yes. As of January 1, 1990, the cost cap is repealed.

2. Can a building official exempt projects from compliance with these regulations based on hardship?

No. The hardship clause in the previous HCD regulations which exempted some projects from compliance with the HCD accessibility regulations has, in most cases, been eliminated. A general definition of "hardship" is given in the glossary of A New Horizon.

3. How many units in an apartment house trigger the HCD accessibility and adaptability standards?

An apartment building, as defined by the Uniform Building Code, contains three or more units. However, apartment buildings containing fewer than five dwelling units are exempt from the HCD regulations.

4. Do the HCD accessibility and adaptability regulations apply to condominiums?

No. Condominiums, whether renter or owner occupied, are not affected by the HCD accessibility standards.

5. Since HCD does not regulate condominiums, may I enforce the applicable provisions of the UBC for condominium projects in my jurisdiction?

No. HCD's regulations supercede all applicable provisions of the UBC.

6. When considering a two story apartment building with 50 units on the first floor and 50 accessible units on the second floor, how do I apply the standards?

In a privately funded apartment house with 50 dwelling units on the primary entrance floor and 50 units on the accessible second floor, a total of five units in the building would have to fully comply. The other 95 dwelling units on primary entrance floors or on other floors which are accessible by ramp, elevator, or special lift would have to comply with the same requirements as in the 5 units, with the exception that there are no requirements in the kitchen in these 95 units. For projects in which a permit is issued on or after July 1, 1990, however, the kitchen in the 95 units will be required to have removable base cabinets under the sink/counter area.

7. If I have a two story apartment building with 5 units on the first floor and 5 units on the second floor which are not accessible by ramp, elevator, or elevator, how would I apply the HCD accessibility and adaptability standards?

One unit on the first floor would have to fully comply with the HCD regulations. The second floor of the apartment house would be exempt because it is not accessible by

ramp, elevator, or special lift. The other four units on the primary entrance floor, however, would have to comply with the same requirements, with the exception of the kitchen. On or after July 1, 1990, however, the kitchen will be required to have removable base cabinets under the sink counter area.

8. If I have a four-unit apartment building and a duplex on a building site, how many units would have to comply with the HCD regulations?

The intent of the regulations is that only apartment buildings are subject to the regulations (three units or more per building), therefore you would not be subject to these regulations because you have only four apartment units on your site.

9. In an apartment house dwelling unit with multiple bathrooms, how many bathrooms in the unit must meet the HCD water closet, bathtub, and lavatory minimum requirements?

The regulations state that the water closet, bathtub, and lavatory minimum space requirements are applicable to one bathroom only in an apartment house dwelling unit with multiple bathrooms.

10. In applying the new HCD regulations, if I have four units constructed on a building site in the first phase of a project, then, later, a builder applies for a permit to build four more apartment dwelling units in the second phase on the same parcel, do all (or any) of the eight of the units have to comply with the new HCD regulations?

The HCD regulations apply to privately funded apartment houses having five or more dwelling units where an application for a building permit is submitted after the effective date of these regulations.

If the builder originally applies for a permit to build four apartment dwelling units, these four units would not have to comply with the new HCD regulations since the regulations apply only to apartments having 5 or more dwelling units. When a builder submits an application for a permit to construct four more units on the same parcel, however, one of the four new units would have to fully comply with the new HCD regulations. The other three new units, if accessible by ramp, elevator, or special lift would have to comply with the same requirements, with the exception of the kitchen. On or after July 1, 1990, removable base cabinets under the kitchen sink counter area would be required in these other units.

11. If I have further questions regarding these regulations, who should I contact?

Your building department should be able to provide assistance in clarifying the regulations. In addition, the Department of Housing and Community Development may publish periodic bulletins which clarify the standards. Many professional associations, such as CALBO, CBIA, and CCAIA also have staff which are qualified to respond to questions regarding these regulations. If an individual is unable to receive a satisfactory response from these groups, the Department of Housing and Community Development will respond to inquiries about their regulations.

Other Common Questions (Continued)

12. What is a co-op?

HCD defines a co-op, for purposes of these regulations, as a time-share unit, in which the owner belongs to a group or association and pays for the right to use the unit for a limited amount of time during a year. Usually these units are identified in the planning stage and are approved for conditional use.

13. What is a condominium?

A condominium is a unit in which the owner owns only the airspace occupied by the unit. A condominium has no dedicated property lines, and no private utilities.

14. What is a site constraint?

A site constraint is one of three conditions: (1) where a primary entrance being served is located more than 30 inches above grade; (2) where a path of travel is located on a slope of greater than 15 percent natural grade; or (3) where the natural grade or terrain does not allow for the installation of a 1:12 ramp. The building official will have to use some judgement to determine if natural site constraints exist, or if they are contrived to prevent access by persons with disabilities. Only those apartment units in which the primary entrance is above or below grade (per UBC definition) may be completely exempt from these regulations.

15. Would a local ordinance preempt compliance with the HCD accessibility and adaptability regulations?

No. If a local jurisdiction wants to place a more restrictive requirement on a building type, for example, it may do so only for climatic, topographical, or geological conditions, and the jurisdiction must file its justification with HCD.

16. If a local jurisdiction has a landscape ordinance which causes access to a privately funded apartment unit to be obstructed, would those units be exempted from compliance with the HCD regulations?

No. Although planning and zoning laws are the responsibility of the local jurisdiction, a local landscape ordinance which causes a unit to be inaccessible from the parking facility would be in conflict with state regulations.

17. If you have four new units which are added to an existing project, and the new units have site constraints due to grade, how many units would have to comply?

None. The four new units would be exempt. The existing units, also, would be exempt because these regulations do not require retrofit of the existing units.

18. Do outside gates have to comply with the requirement for a door buzzer, bell, chime, according to these regulations?

No. The regulations apply only to the primary entrance to the dwelling unit, and to individual living units. Therefore, if you have a main entry or security door at the entrance to a unit, it must comply. The individual unit, also, must have the required hardware, connected to permanent wiring.

19. The state regulations require a handrail height of 30 to 34 inches. Since the UBC handrail height is now different, will this have any impact on the state regulations?

No. When the state adopts the 1991 code adoptions and amendments, HCD may decide to go with the UBC measurements, or they may not. In the meantime, you must use the measurements shown in Title 24 for handrail heights.

20. Relative to the electrical receptacle outlet height minimum of 12 inches, to what point do I measure the 12 inches from the floor?

You must measure the 12 inches from the floor to the center of the receptacle.

21. In a U-shaped kitchen which has 48 inch clear space, is it acceptable to take the 12 inches out of the kitchen cabinets on the opposite side of the kitchen, rather than under the sink?

Yes. As long as a 60-inch circle can be made, and the circle is centered at the sink, it is permissible to provide the clearance on the counter opposite the sink.

22. Is there any restriction on where the two 15 inch bread boards are placed, when they are installed in lieu of counter space?

No. However, the breadboards shall be usable by a physically disabled person who is seated in a wheelchair.

23. What is the difference between the unit which is in the "5 percent" category, and the other unit that is in the "95 percent" category?

The dwelling units that fall within the 5 percent category must have full access and be adaptable for persons with physical disabilities.

The remaining number of units that are accessible, whether on primary entrance floors, or accessible by ramp, elevator, or special lift, also must fully comply with the HCD regulations, with the exception of the kitchen. On July 1, 1990, dwelling units in the 95 percent category shall have base cabinets under the sink and counter area in the kitchen that are removable, and the floor underneath shall be finished to the wall.

VI. WHERE TO OBTAIN ASSISTANCE

Resource Materials

- HCD, 1989, A New Horizon, State of California, Department of Housing and Community Development, Sacramento. Available by writing to the following address:

**Miguel Mejia
Department of Housing and Community Development
Division of Codes and Standards
P.O. Box 1407
Sacramento, CA 95812-1407**

- CALBO, 1989, Seminar Curriculum and Training Workbook, California Building Officials, Sacramento. Available by sending a check for \$10 (postage and handling) to the following address:

**CBCI Professional Development Fund
2215 21st Street
Sacramento, CA 95818**

- ICBO, 1988, Uniform Building Code, International Conference of Building Officials, Whittier, California.
- ICBO, 1988, State of California/Code Amendments to the 1988 editions of the Uniform Building, Mechanical and Plumbing Codes, International Conference of Building Officials, Whittier, California.

ICBO publications are available by writing to the following address:

**International Conference of Building Officials
5360 South Workman Mill Rd.
Whittier, CA 90601**

To order by phone, call the ICBO Order Department at (213) 692-ICBO. 7:00 a.m. to 5:00 p.m. Pacific Time.

Roster of Individuals and Associations

For written interpretations from the adopting agency:

Ed King, Assistant Chief
Division of Code and Standards
Department of Housing and Community Development
P.O. Box 1407
Sacramento, CA 95812-1407
(916)445-9471

Miguel Mejia, State Housing Law Manager
Division of Codes and Standards
Department of Housing and Community Development
P.O. Box 1407
Sacramento, CA 95812-1407
(916)445-9471

For assistance on using Title 24:

California Building Standards Commission
428 J Street, Suite 450
Sacramento, CA 95814
(916)323-6363

For assistance on pending federal amendments:

Robert E. Raymer, P.E. Technical Director
California Building Industry Association
1107 Ninth Street, Suite 1060
Sacramento, CA 95814
(916)443-7933

Additional other assistance and referrals:

California Building Officials
2215 21st Street
Sacramento, CA 95818
(916)457-1103

For assistance on accessibility regulations in publicly funded buildings and public buildings:

Office of the State Architect
Disabled Access Compliance Unit
400 P Street, 5th Floor
Sacramento, CA 95814
(916)445-7523